

Battery Thermal Wrap

HOTSTART battery thermal wraps prolong battery life and improve cranking power in the coldest conditions. As the temperature drops, batteries that aren't heated lose cranking power, reducing startability. The UL Recognized wrap maintains battery temperature at 80 °F (27 °C) for maximum cold cranking amps. The heater is designed to overlap the battery allowing the thermostat to stay in contact with the battery for constant heating.

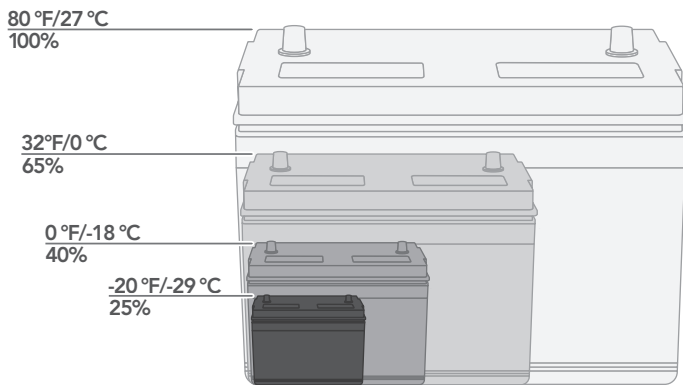

Battery cranking power is reduced in colder temperatures.



APPLICATION

The battery wrap is designed to heat lead acid batteries for diesel and gas engines in genset, heavy duty mobile equipment, marine and industrial applications.

SPECIFICATIONS

- Heat Power: 50W, 65W, 80W, 100W, 130W, 160W
- Voltage: 120 V, 240 V
- Fixed Thermostat: 60–80 °F (16–27 °C)
- Three-pin cord: 9" (229 mm)

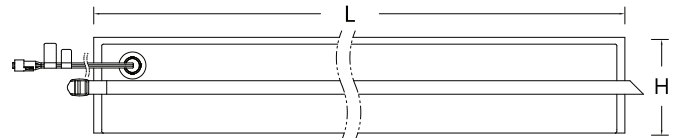

FEATURES

- UL-C/US recognized*
- Power cord available with 120 or 240 V NEMA plug or 240 V Schuko plug, sold separately from wrap – refer to chart on reverse to select corresponding cord
- Thermostat eliminates damage caused by overheating and acid spill
- Durable, fire-retardant vinyl cover resists oils and acids
- Included strap and buckle allows wrap to be adjusted or removed easily

* Euro cord not UL Recognized.

DIMENSIONS & WEIGHT

Length (L)	Height (H)	Weight
refer to chart	7.5"	1.1–2 lbs
on reverse side	191 mm	0.50–0.91 kg

Recommended minimum clearance of 1.5" (38 mm) when placed inside a case or box.

Battery Thermal Wrap



PART NUMBERS

UL RECOGNIZED BATTERY THERMAL WRAP — WITH THERMOSTAT

Thermostat range: 60 °F - 80 °F (16 °C - 27 °C)

Battery Group*	Model Number	Volts	Watts	Wrap Length	72" Power Cord**	Replacement Strap
22NF	BW0513006S-000	120	50	30" (762 mm)	BPC-61	BW-S-55
	BW0523006S-000	240	50	30" (762 mm)	BPC-62	
24, 24F, 24H, 24R, 24T, 25, 27, 27H, 34, 34R, 35, 75, 78, GC2	BW0613806S-000	120	65	38" (965 mm)	BPC-61	BW-S-55
	BW0623806S-000	240	65	38" (965 mm)	BPC-62	
30H, 31	BW0814606S-000	120	80	46" (1168 mm)	BPC-61	BW-S-55
	BW0824606S-000	240	80	46" (1168 mm)	BPC-62	
2E	BW1015406S-000	120	100	54" (1372 mm)	BPC-61	BW-S-80
	BW1025406S-000	240	100	54" (1372 mm)	BPC-62	
4D, 6D	BW1316206S-000	120	130	62" (1575 mm)	BPC-61	BW-S-80
	BW1326206S-000	240	130	62" (1575 mm)	BPC-62	
8D	BW1617006S-000	120	160	70" (1778 mm)	BPC-61	BW-S-80
	BW1627006S-000	240	160	70" (1778 mm)	BPC-62	

EURO BATTERY THERMAL WRAP FOR SCHUKO PLUG— WITH THERMOSTAT

Thermostat range: 60 °F - 80 °F (16 °C - 27 °C)

Battery Group*	Model Number	Volts	Watts	Wrap Length	72" Power Cord**	Replacement Strap
22NF	BW0523006S-100	240	50	30" (762 mm)	BPC-62E	BW-S-55
24, 24F, 24H, 24R, 24T, 25, 27, 27H, 34, 34R, 35, 75, 78, GC2	BW0623806S-100	240	65	38" (965 mm)	BPC-62E	BW-S-55
30H, 31	BW0824606S-100	240	80	46" (1168 mm)	BPC-62E	BW-S-55
2E	BW1025406S-100	240	100	54" (1372 mm)	BPC-62E	BW-S-80
4D, 6D	BW1326206S-100	240	130	62" (1575 mm)	BPC-62E	BW-S-80
8D	BW1627006S-100	240	160	70" (1778 mm)	BPC-62E	BW-S-80

* Not all battery groups listed. For wrap sizing, consult the factory.

** Power cord sold separately. For other cord lengths, consult the factory.

Battery wrap comes with a 9" (229 mm) pigtail. BPC-61 and BPC-62 have a NEMA plug. BPC-62E has a Schuko plug. **Please order the necessary power cord to complete your wrap assembly.**